





12AVR-125L/LLP 12AVR-145L/LLP VALVE-REGULATED BATTERIES

INSTALLATION AND OPERATING INSTRUCTIONS

⚠ DANGER				
HIGH VOLTAGE... RISK OF SHOCK. DO NOT TOUCH UNINSULATED TERMINALS OR CONNECTORS.	SHIELD EYES. EXPLOSIVE GASES CAN CAUSE BLIND- NESS OR INJURY.	NO SPARKS FLAMES SMOKING	SULFURIC ACID CAN CAUSE BLINDNESS OR SEVERE BURNS.	FLUSH EYES IMMEDIATELY WITH WATER. GET MEDICAL HELP FAST.
DO NOT REMOVE VENT VALVE. WARRANTY VOID IF VENT VALVE IS REMOVED.		VENTILATE WELL WHEN IN AN ENCLOSED SPACE AND WHEN CHARGING.		
SEE INSTALLATION, MAINTENANCE AND OPERATION INSTRUCTIONS FOR IMPORTANT SAFETY PRECAUTIONS.		REPAIR SHOULD BE PERFORMED ONLY BY A QUALIFIED SERVICE TECHNICIAN.		



California Proposition 65 Warning

Battery posts, terminals and related accessories contain lead and lead compounds, and other chemicals known to the state of California to cause cancer and birth defects or other reproductive harm. **Wash hands after handling.**

SAFETY PRECAUTIONS

Although all valve-regulated batteries have the electrolyte immobilized within the cell, the electrical hazard associated with batteries still exists. **Work performed on these batteries should be done with the tools and the protective equipment listed below.** Valve-regulated battery installations should be supervised by personnel familiar with batteries and battery safety precautions.

Protective Equipment

To assure safe battery handling, installation and maintenance, the following protective equipment should be available:

1. **Safety glasses or face shields**
2. Acid-resistant gloves
3. Protective aprons
4. Lifting devices
5. Tools with insulated handles

Procedures

The following safety procedures should be followed during installation: **(Always wear safety glasses or face shield.)**

1. Adequately secure battery racks or cabinet enclosures to the floor.
2. Connect support structures to ground system in accordance with applicable codes.
3. Inspect all flooring and lifting equipment for functional adequacy. Specifically review floor loading capacity.
4. **Prohibit smoking and open flames, and avoid arcing in the immediate vicinity of the battery.**
5. Keep the top of the battery clear of all tools and other foreign objects.
6. Provide adequate ventilation and follow recommended charging voltages.
7. Avoid wearing metallic objects such as jewelry while working on the battery.
8. **Never** remove or tamper with the pressure relief valves.
9. These batteries are sealed and contain no free electrolyte. Under normal operating conditions they do not present any acid danger. However, if the battery case or cover is damaged, acid could be present. **Sulfuric acid is harmful to the skin and eyes. Flush affected area with water immediately and consult a physician if splashed in the eyes.**
10. Do not use CO₂ to extinguish battery fires. Use a halon-generated fire extinguisher system.

SPECIFICATIONS

Product Code	Nominal Voltage	Ampere Hours @ 8-hour Rate	Ampere Hours @ 10-hour Rate	Length	Width	Height	Total Weight	Acid Volume
12AVR-125L	12V	120	125	16.82 in. 427.2 mm	6.97 in. 177.0 mm	10.10 in. 256.5 mm	120lbs. 54.4 kg	2 gal. 7.57 L
12AVR-125LLP	12V	120	125	17.90 in. 454.7 mm	6.97 in. 177.0 mm	9.36 in. 237.7 mm	120lbs. 54.4 kg	2 gal. 7.57 L
12AVR-145L	12V	145	150	16.82 in. 427.2 mm	6.97 in. 177.0 mm	10.10 in. 256.5 mm	100lbs. 45.4 kg	2.2 gal. 8.25 L
12AVR-145LLP	12V	145	150	17.90 in. 454.7 mm	6.97 in. 177.0 mm	9.36 in. 237.7 mm	100lbs. 45.4 kg	2.2 gal. 8.25 L

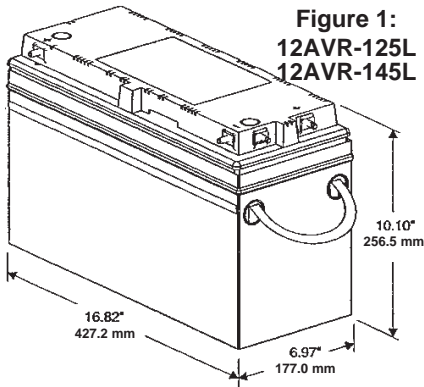

Figure 1:
12AVR-125L
12AVR-145L

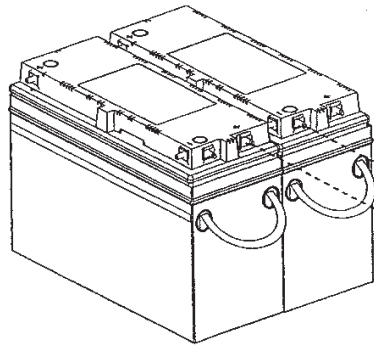

Figure 2:
12AVR-125L
12AVR-145L
Bus Bar

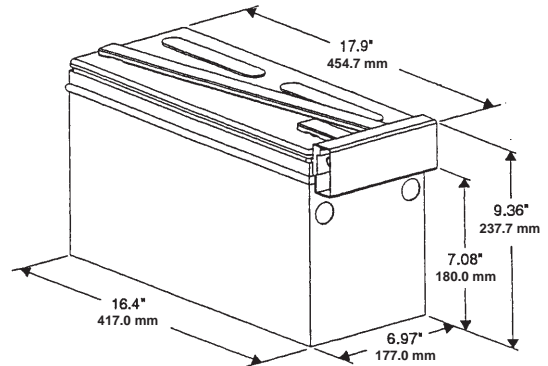

Figure 4: 12AVR-125LLP
12AVR-145LLP

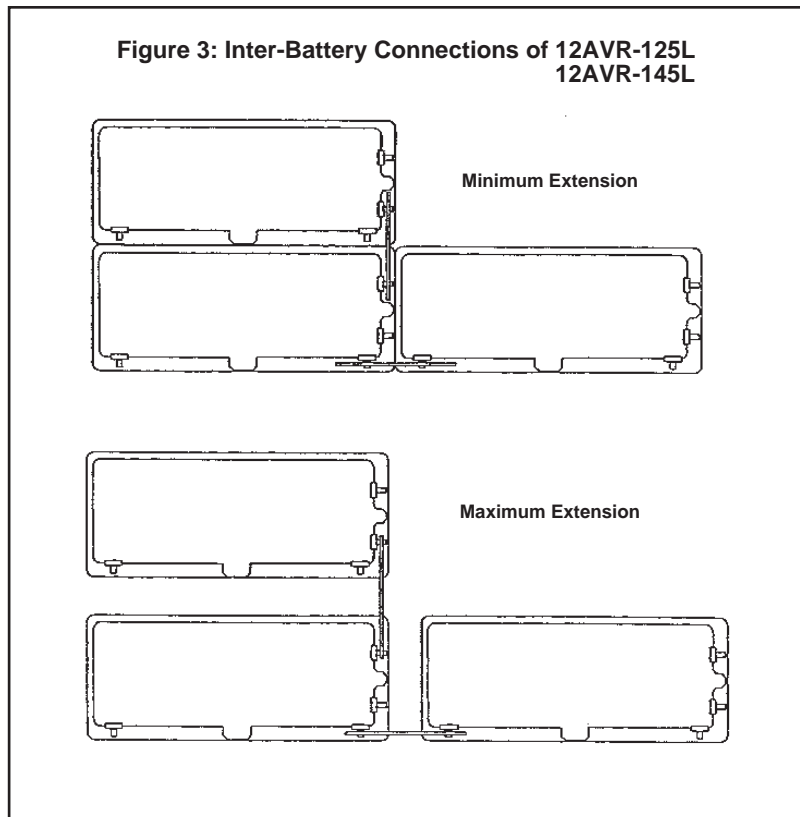

Figure 3: Inter-Battery Connections of 12AVR-125L
12AVR-145L

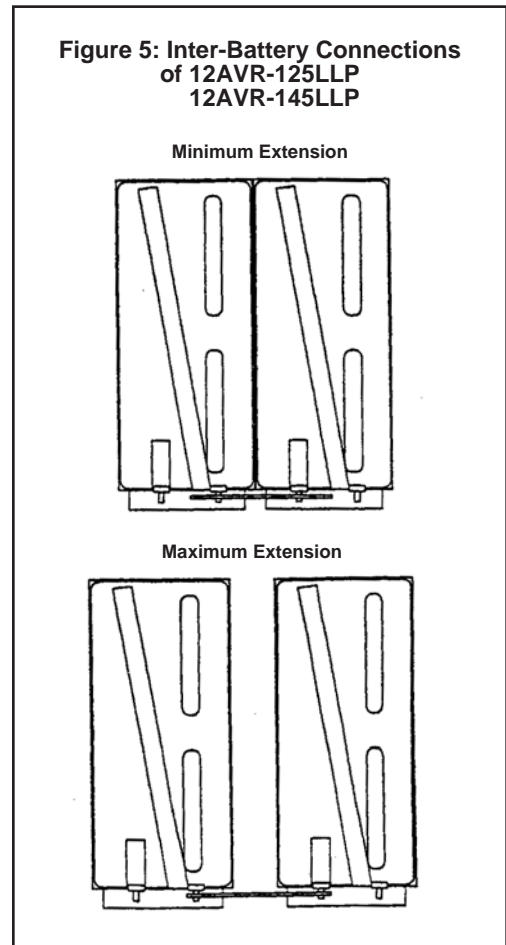

Figure 5: Inter-Battery Connections
of 12AVR-125LLP
12AVR-145LLP

BATTERY INSTALLATION

The 12AVR-125L/LLP & 12AVR-145L/LLP batteries are provided with inter-battery bus bars to connect batteries in series to create battery strings. One bus bar is provided with the accessory kit and comes complete with hardware to create various size strings of batteries as specified for the application (e.g., 24V or 48 V battery strings). (See Figure 2.)

When planning or installing the 12AVR-125L or 12AVR-145L battery, refer to Figure 3 to determine battery spacing. These two figures show the maximum and minimum spacing of the batteries when they are positioned end to end either short face to short face or long face to long face.

NOTE: Do not refer to these figures for help in connecting the batteries in strings. These figures are not intended to depict wiring options.

Battery Installation Procedure

1. Before proceeding with the installation of the battery, review or determine the arrangement of the batteries for the application.
2. The battery terminals are pre-coated with NO-OX-ID A® compound. If terminals appear dirty, clean surface areas of the exposed terminals with a non-abrasive cloth and re-coat with NO-OX-ID A® (provided with accessory kit).
3. If the case is dirty when removed from the shipping container, clean the case with a cloth dampened with water before installing it in the battery stand.

Caution: Use only water to clean batteries.

4. Gently slide batteries into position as determined in Step 1. The battery should be oriented so that the negative (-) post of one battery is adjacent to the positive (+) post (post of opposite polarity) of next or adjacent battery.

Caution: Do not lift the battery (ies) alone or with one handle. Two persons are always required to lift the battery. Hoist battery on pallets or use lifting sling with spreader bar.

5. Coat inter-battery bus bars, provided with battery kit, with NO-OX-ID A® before assembling them to batteries.
6. Using 1/4-20 hardware and inter-battery bus bar provided, connect batteries into strings as determined in Step 1. (See Figure 2), Torque connections to 60 in-lbs.
7. Using cabling provided with the plant, connect the battery string to the plant bus as determined in Step 1. Terminate these cable leads with the appropriate wire lugs.
8. Dress the cable leads from the batteries to the plant bus work and torque battery connections to 60 in-lbs. See specifications provided with the plant for plant bus work torquing requirements.

CHARGING

Batteries shall be charged by a constant potential method. A potential of 13.62 ± 0.06 volts per 12V 12AVR-125L/LLP battery or 13.50 ± 0.06 volts per 12 V 12AVR-145L/LLP battery for constant voltage is recommended for float-standby applications at 77°F (25 C). For systems without a temperature compensation device, the float voltage should be reduced by $18\text{mV}/^\circ\text{C}/\text{battery}$ for temperatures above 25°C (77°F). This adjustment is automatically performed in systems with either a step or a slope compensation device.

Caution: Failure to reduce float voltage in systems without temperature compensation may result in premature failure or thermal run-away.

Operating 12AVR-125L/LLP or 12AVR-145L/LLP batteries for any length of time outside the recommended voltages and/or temperatures will result in reduced performance and premature failure and may reduce or void the warranty.

BATTERY STRING FLOAT VOLTAGE

It is extremely important to maintain the battery at the proper float voltage. The recommended float voltage per battery is 13.62 volts \pm 0.06 volts at a battery temperature of 77°F (25°C) for 12AVR-125L/LLP and 13.50 volts \pm 0.06 volts for 12AVR-145L/LLP.

To determine the battery string float voltage, use the following equation:

$$\text{Battery String Float Voltage} = \text{recommended float voltage per battery} \times \text{number of batteries}$$

For example: A 4-battery (48-volt) string of 12AVR-125L/LLP batteries should be floated at:

$$\text{Battery String Voltage} = 13.62 \text{ volts} \times 4 \text{ batteries}$$

$$\text{Battery String Voltage} = 54.48 \text{ volts}$$

For example: A 4-battery (48-volt) string of 12AVR-145L/LLP batteries should be floated at:

$$\text{Battery String Voltage} = 13.50 \text{ volts} \times 4 \text{ batteries}$$

$$\text{Battery String Voltage} = 54.00 \text{ volts}$$

APPENDIX A



BATTERY MAINTENANCE REPORT

Date _____ No. of Calls _____
 Company _____ Type _____
 Address _____ Date New _____
 Battery location and/or number _____ Date Installed _____

Individual Battery Readings

Charger Output _____ Amp Air Temperature _____ °F
 Total Battery String Voltage _____ Panel Meter Volts _____

Year _____			Year _____			Year _____			Year _____		
Unit Number	Volts	Ohms or Mhos	Unit Number	Volts	Ohms or Mhos	Unit Number	Volts	Ohms or Mhos	Unit Number	Volts	Ohms or Mhos
1			1			1			1		
2			2			2			2		
3			3			3			3		
4			4			4			4		
5			5			5			5		
6			6			6			6		
7			7			7			7		
8			8			8			8		
9			9			9			9		
10			10			10			10		
11			11			11			11		
12			12			12			12		
13			13			13			13		
14			14			14			14		
15			15			15			15		
16			16			16			16		
17			17			17			17		
18			18			18			18		
19			19			19			19		
20			20			20			20		
21			21			21			21		
22			22			22			22		
23			23			23			23		
24			24			24			24		
25			25			25			25		
26			26			26			26		
27			27			27			27		
28			28			28			28		
29			29			29			29		
30			30			30			30		
31			31			31			31		
32			32			32			32		
33			33			33			33		
34			34			34			34		
35			35			35			35		
36			36			36			36		
37			37			37			37		
38			38			38			38		
39			39			39			39		
40			40			40			40		
Avg. Voltage			Avg. Voltage			Avg. Voltage			Avg. Voltage		

Readings Taken By _____ Remarks/Recommendations _____

Readings should be taken at installation and annually thereafter.

EAST PENN manufacturing co., inc.

Lyon Station, PA 19536-0147 • Phone: 610-682-6361 • Fax: 610-682-4781

Order Department Hotline: 610-682-4231

www.dekabatteries.com • Email: sales@eastpennunigy.com