

# Deka unigy®

## HIGH RATE SERIES

The Deka Unigy High Rate Series line of absorbed valve-regulated, lead-acid batteries is designed specifically for high-rate uninterruptible power supplies (UPS). These batteries are housed in polypropylene or flame-retardant polypropylene (rated 28 LOI), 12-volt monoblocks. Absorbed glass-mat construction lowers internal resistance for superior high-rate, short-term discharges. I.C.C.O., I.M.D.G., I.A.T.A. and D.O.T. air transport approval pending.

### Specifications

- NOMINAL VOLTAGE: 12-Volt
- FLOAT CHARGE VOLTAGE: 13.50 @ 77°F (25°C)
- EQUALIZE CHARGE VOLTAGE: 14.4
- OPERATING TEMPERATURE: 50° to 95°F (10°C to 35°C)
  - TERMINAL: Molded lead terminal with 1/4 x 20 brass inserts
  - TORQUE VALUE: 60 inch lbs.
  - RIPPLE: Limited to 0.5% RMS or 1.5% of the float voltage
  - SAFETY VENT: Flame arresting, low-pressure, self sealing on flame-retardant Low-pressure, self sealing on standard



DATA SHEET FOR PART NUMBER:  
**31HR5000\***

\* Add "S" in part number for standard vent (31HR5000S)  
Standard: Black Cover, Grey Case  
Flame Retardant: Charcoal Cover and Case

### Discharge Ratings in Watts Per Cell To Various End Voltages [at 77°F (25°C)]

Volts Per Cell (V.P.C.)	1 Min.	5 Min.	10 Min.	15 Min.	20 Min.	30 Min.	40 Min.	50 Min.	60 Min.
1.90		442	333	290	257	207	175	150	131
1.85		501	410	349	306	244	203	174	152
1.80	704	581	481	406	350	276	227	194	168
1.75	836	663	530	440	375	290	236	200	173
1.70	946	727	569	464	391	298	241	203	176
1.67	983	760	588	<b>475</b>	397	301	240	205	177
1.60	1081	830	620	492	406	306	246	206	178

Note: Above ratings conform to IEEE-485 standards.

### Discharge Ratings in Amperes To Various End Voltages [at 77°F (25°C)]

Volts Per Cell (V.P.C.)	15 Min.	30 Min.	60 Min.	3 Hrs.	8 Hrs.	12 Hrs.	20 Hrs.	48 Hrs.	100 Hrs.
1.90	150.00	106.00	66.00	30.10	13.40	9.33	5.81	2.51	1.22
1.85	183.00	126.00	78.00	33.30	14.70	10.20	6.33	2.72	1.32
1.80	216.00	144.00	87.00	35.40	15.30	10.60	6.56	2.81	1.37
1.75	238.00	153.00	90.00	36.10	15.60	10.80	6.66	2.85	1.39
1.70	254.00	158.00	91.00	36.50	15.70	10.80	6.69	2.87	1.39
1.67	261.00	160.00	92.00	36.70	15.70	10.90	6.71	2.88	1.40
1.60	273.00	163.00	93.00	37.00	15.80	10.90	6.75	2.89	1.40

Note: Above ratings conform to IEEE-485 standards.

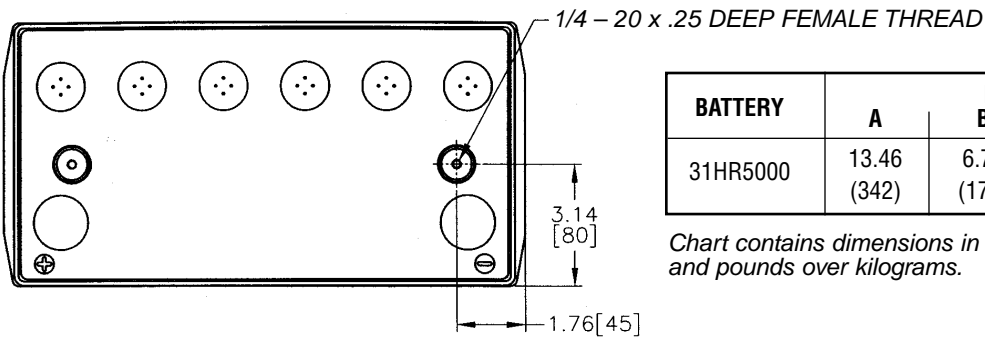

BATTERY	DIMENSIONS				WEIGHT
	A	B	C	D	
31HR5000	13.46 (342)	6.77 (172)	11.25 (286)	11.08 (281)	98 (44.5)

Chart contains dimensions in inches over millimeters and pounds over kilograms.

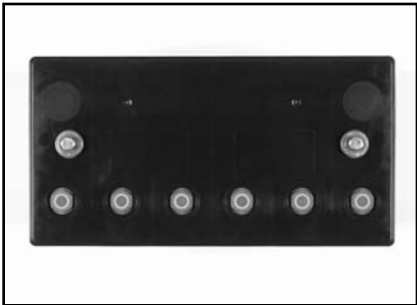
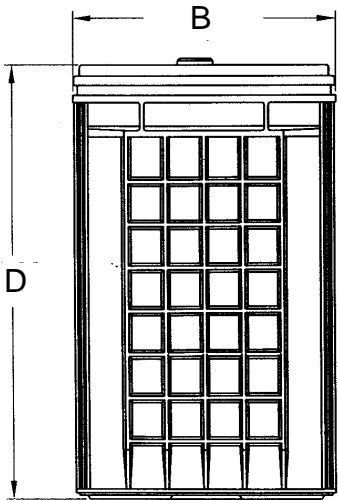
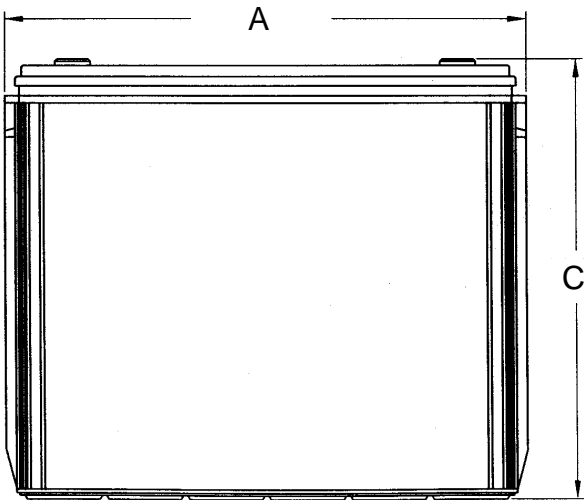

Part Number: **31HR5000S**  
Standard: Black Cover, Grey Case



Part Number: **31HR5000**  
Flame Retardant: Charcoal Cover and Case



QUALITY SYSTEM  
CERTIFIED TO  
**ISO 9001**  
**QS 9000**



# EAST PENN manufacturing co., inc.

Lyon Station, PA 19536-0147 • Phone: 610-682-6361 • Fax: 610-682-4781

Order Department Hotline: 610-682-4231

WWW: <http://www.eastpenn-deka.com>

E-mail: [epmstat@eastpenn-deka.com](mailto:epmstat@eastpenn-deka.com)